

# IS-SL - Intrinsically Safe Protectors



## Intrinsically Safe Signal Line Protectors

Novaris slimline surge protection devices (SPDs) provide surge protection for most twisted pair signaling schemes. Certified to be intrinsically safe Novaris IS SPDs can be installed in the hazardous zone or the field side of the IS barrier. This not only provides protection for the PLC or RTU I/O, it also provides protection for the IS barrier.

### IEC Ex and ATEX certified

Novaris 'IS-' products are certified intrinsically safe according to IEC Ex and ATEX; the group IIC T4 certification makes it acceptable for use with all gas/air mixtures.

### Two different earthing options

With two different base options the SL protectors offer either direct earthing via DIN rail, for the most effective, low impedance earth connection (-G base) or a connection via GDT to the DIN rail, offering isolation under normal conditions and equipotential bonding during a surge (-EC90 base).

### Slimline pluggable modules

The plug-in design provides simple and rapid replacement and testing - no rewiring needed. This also provides a convenient method of field equipment isolation if required.

## Diagram / Installation

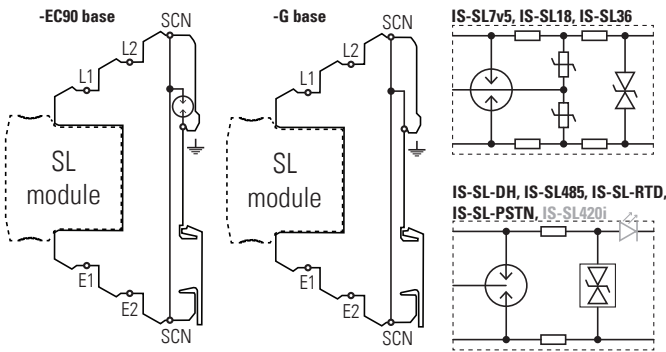

## Dimensions

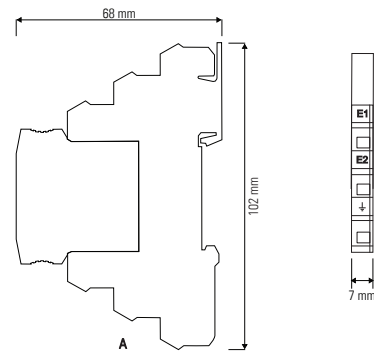

## Ordering Information

Model	Signal Type			Base - direct earthing	Base - indirect earthing
IS-SL7v5	0 - 6 V analog		6 V digital	-G	-EC90
IS-SL18	0 - 12 V analog		12 V digital	-G	-EC90
IS-SL36	0 - 20 mA	4 - 20 mA	24 V digital	-G	-EC90
IS-SL-PSTN	Public Switched Telephone Network			-G	-EC90
IS-SL-iSwitch	Public Switched Telephone Network			-G	-EC90
IS-SL485	RS 485		RS422	-	-EC90
IS-SL-DH	RS232	Data Highway	HART	-G	-EC90
IS-SL-RTD	RTD Applications		Thermocouple	-G	-EC90
IS-SL420i <sup>1)</sup>	0 - 20 mA		4 - 20 mA	-G	-EC90

<sup>1)</sup> LED indicates status of instrument loop

## Product Specifications

Model		IS-SL7v5	IS-SL18	IS-SL36	IS-SL-PSTN	IS-SL-Switch	IS-SL-485	IS-SL-DH	IS-SL-RTD	IS-SL-420i
-------	--	----------	---------	---------	------------	--------------	-----------	----------	-----------	------------

### Electrical Specifications

Connection Type		Series	Series	Series	Series	Series	Series	Series	Series	Series
Number of lines		1 pair	1 pair	1 pair	1 pair	1 pair	1 pair	1 pair	1 pair	1 pair
Modes of protection		Transverse and common mode								
Maximum continuous voltage (DC)	$U_c$	7 V	16 V	34 V	200 V	200 V	8 V	34 V	3 V	34 V
Maximum continuous voltage (AC)	$U_c$	5 V	11 V	24 V	140 V	140 V	6 V	24 V	2 V	–
Maximum discharge current (8/20 $\mu$ s)	$I_{max}$	5 kA per line (10 kA common mode)								
Maximum discharge current (10/350 $\mu$ s)	$I_{imp}$	1 kA per line (2 kA common mode)								
Impulse durability		C2 10 x 5 kA 8/20 $\mu$ s D1 2 x 1 kA 10/350 $\mu$ s								
Maximum load current	$I_L$	250 mA	250 mA	250 mA	250 mA	180 mA	250 mA	250 mA	250 mA	30 mA
L-L Voltage protection level @ 1 kV/ $\mu$ s	$U_p$	25 V	40 V	55 V	300 V	90 V	30 V	60 V	30 V	45 V
L-L Voltage protection level @ 3 kA 8/20 $\mu$ s	$U_p$	25 V	40 V	55 V	450 V	170 V	30 V	60 V	30 V	45 V
L-L Voltage protection level @ 100 V/ s		8 V	20 V	40 V	330 V	230 V	15 V	40 V	4 V	40 V
L-PE Voltage protection level @ 1 kV/ $\mu$ s	$U_p$	25 V	40 V	55 V	300 V	350 V	350 V	350 V	350 V	350 V
L-PE Voltage protection level @ 3 kA 8/20 $\mu$ s	$U_p$	25 V	40 V	55 V	450 V	600 V	600 V	600 V	600 V	600 V
L-PE Voltage protection level @ 100 V/ s		8 V	20 V	40 V	330 V	230 V	230 V	230 V	230 V	230 V
AC durability		5 x 1 s, 1 Arms								
Overstressed fault mode		Mode 3 (open circuit)								
Response time	$t_A$	< 5 ns	< 5 ns	< 5 ns	< 5 ns	< 5 ns	< 5 ns	< 5 ns	< 5 ns	< 5 ns
Line resistance		8.2 $\Omega$	8.2 $\Omega$	8.2 $\Omega$	8.2 $\Omega$	9.1 $\Omega$	3.9 $\Omega$	3.9 $\Omega$	3.9 $\Omega$	7 $\Omega$
Line inductance		–	–	–	–	–	–	–	–	–
L-L capacitance		40 nF	17 nF	9 nF	115 pF	4.5 pF	20 pF	15 pF	24 pF	440 pF
L-PE capacitance		40 nF	17 nF	9 nF	115 pF	4.5 pF	4.5 pF	4.5 pF	4.5 pF	440 pF
Insertion loss @ 150 $\Omega$		< 0.5 dB (< 10 kHz)	< 0.5 dB (< 30 kHz)	< 0.5 dB (< 60 kHz)	< 0.5 dB (< 1MHz)	< 0.5dB (< 10 MHz)	< 0.5dB (< 1 MHz)	< 0.5dB (< 1 MHz)	< 0.5dB (< 1 MHz)	< 0.5dB (< 600 kHz)
3 dB Frequency @ 150 $\Omega$	$f_c$	50 kHz	120 kHz	220 kHz	18 MHz	100 MHz	60 MHz	60 MHz	60 MHz	6.5 MHz

### Safety Parameters

Max. input voltage	$U_i$	30 V	30 V	30 V	17.2 V	30 V	30 V	30 V	30 V	34 V
Max. input current	$I_i$	1.639 A	1.639 A	1.639 A	1.639 A	1.639 A	1.639 A	1.639 A	1.639 A	1.639 A
Max. input power	$P_i$	1.3 W	1.3 W	1.3 W	1.3 W	1.3 W	1.3 W	1.3 W	1.3 W	1.3 W
Capacitance	$C_i$	0	0	0	210 nF	0	0	0	0	0
Inductance	$L_i$	0	0	0	0	0	0	0	0	0

### Mechanical Specifications

Operating temperature @ $I_L$		-20 to +40 °C								
Humidity Range		5 to 95% non-condensing								
Connection type / capacity		0.25 – 2.5 mm <sup>2</sup> Cage Clamp								
Terminal screw torque		0.5 Nm								
Environmental		IP 20 / indoor								
Mounting		TS35 DIN rail								
Earthing		- Direct earth connection via DIN rail and screw terminals with -G base option - 90 V isolation between DIN rail earth and shield with -EC90 base option								
Enclosure / colour		Polycarbonate UL 94 V-0 / blue								

### Accreditations

TÜV 14 ATEX 7569 X		II 1 G Ex ia IIC T4 Ga								
IECEX ITA 14.0011X		Ex ia IIC T4								

### Standards

Directive 94/9/EC		Equipment and protective systems intended for use in potentially explosive atmospheres								
IEC 60079-0		Explosive atmospheres - Part 0: Equipment - General requirements								
IEC 60079-11		Explosive atmospheres - Part 11: Equipment protection by intrinsic safety 'i'								
IEC 61643-21:2012		SPD connected to telecommunications and signalling networks - Cat C2, D1								
AS/NZS 1768:2007		Signalling/Telecommunications surge protection								
UL 1449 3 <sup>rd</sup> edition & UL 497B		Protectors for data communications and fire-alarm circuits								
ITU-T K.44: 2012		Resistibility tests for telecommunication equipment exposed to overvoltages and overcurrents								

### Shipping

Weight		35 g	35 g	35 g	35 g	35 g	35 g	35 g	35 g	35 g
Customs Tariff		85363000	85363000	85363000	85363000	85363000	85363000	85363000	85363000	85363000

